

**M.ELEVEN**

Ashley DiVito

72" x 48" MIRROR

URINAL

TOILET PARTITIONS

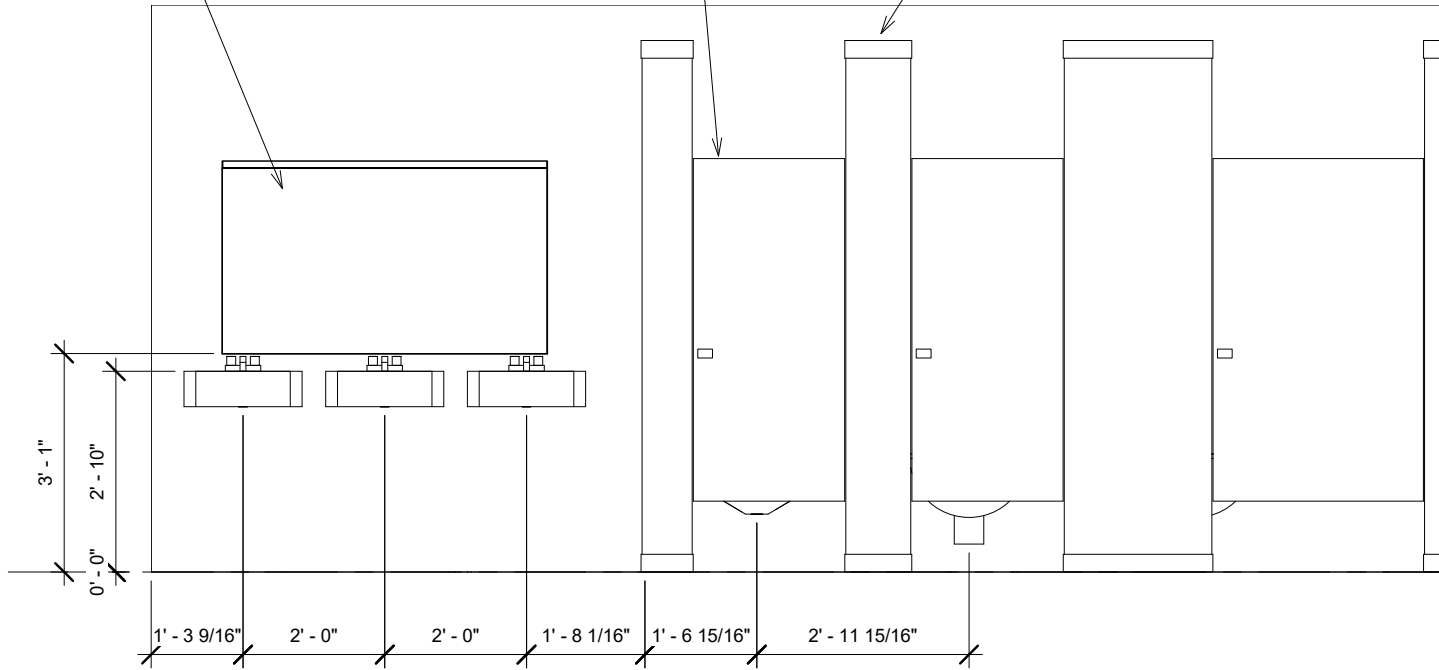

MEN'S TOILET - TYPICAL

elevation

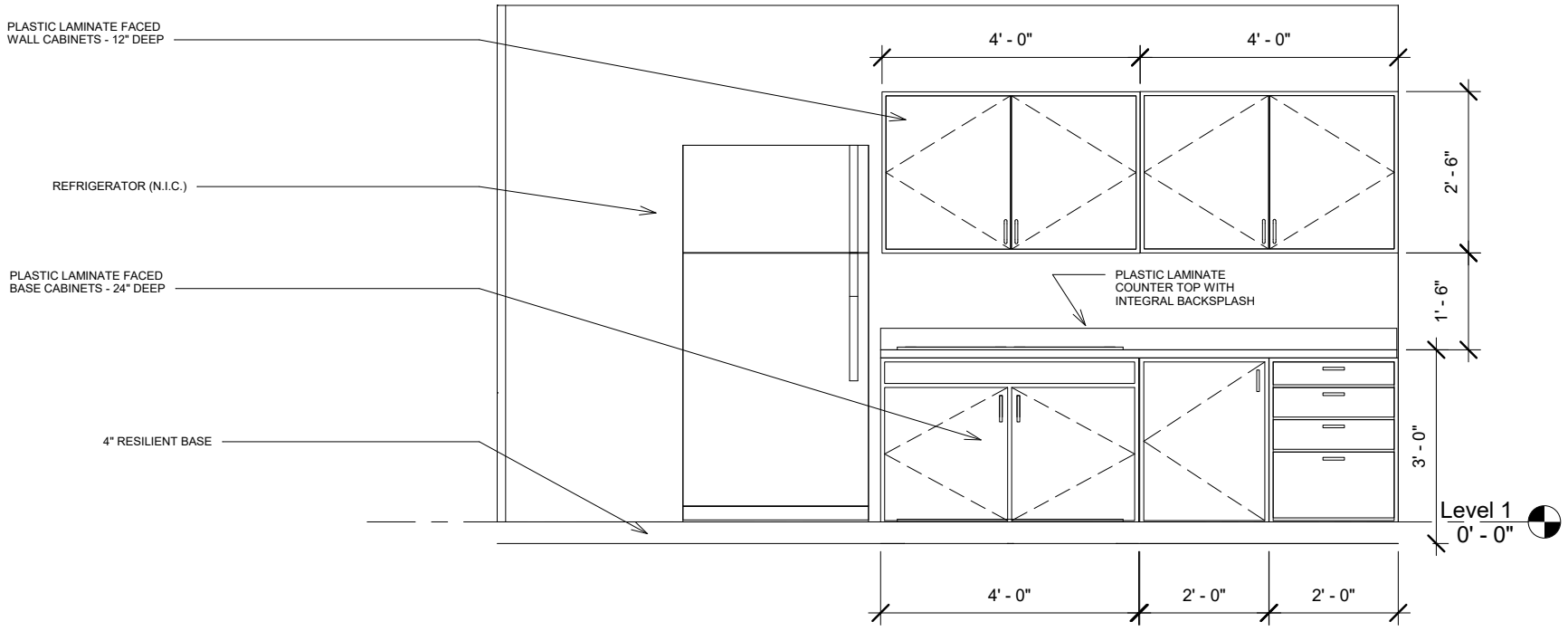

BREAK ROOM - EAST

# elevation

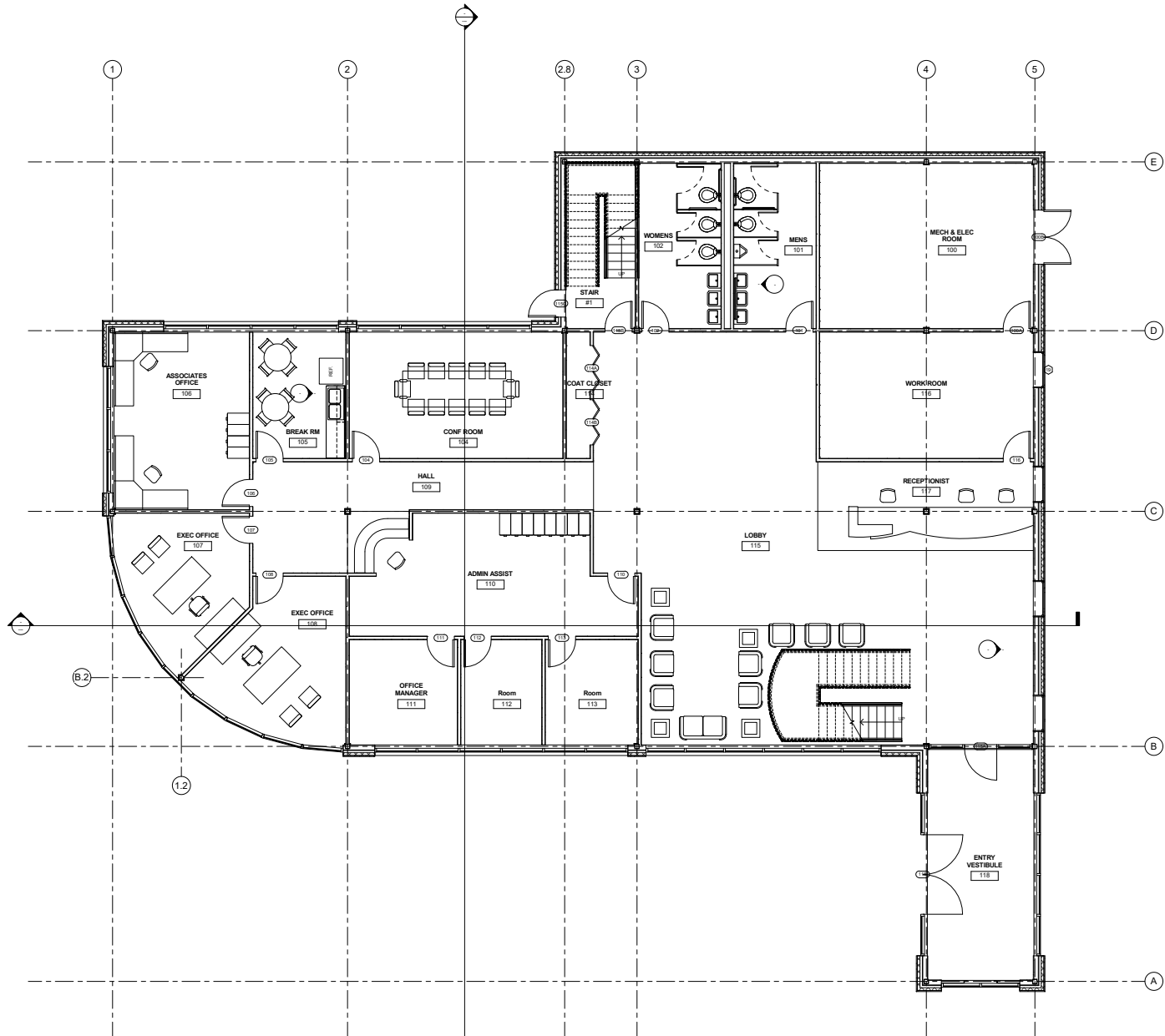

LEVEL ONE.

# floor plan

# floor plan

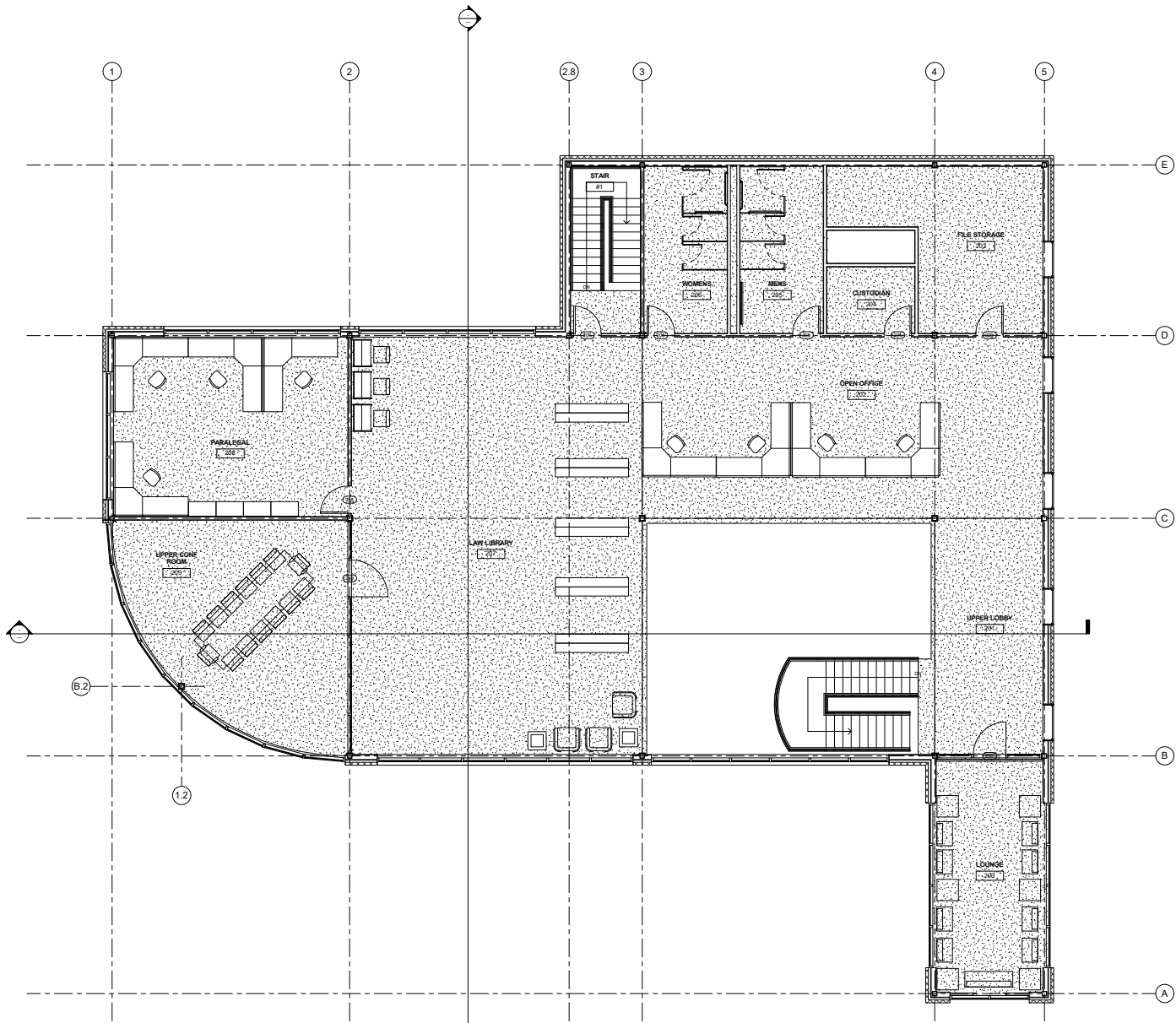

LEVEL TWO.

# floor plan

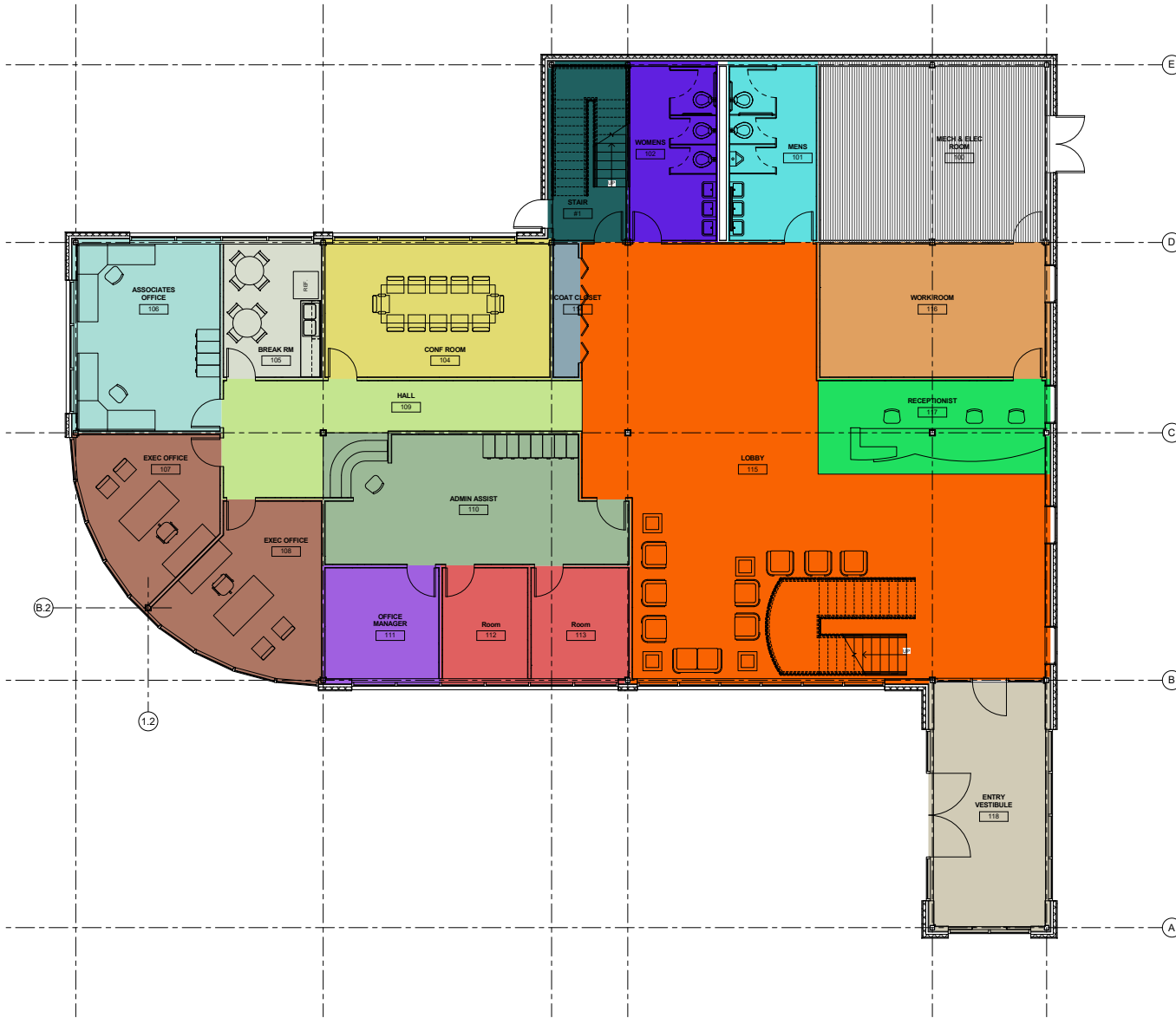

## Room Legend

- ADMIN ASSIST
- ASSOCIATES OFFICE
- BREAK RM
- COAT CLOSET
- CONF ROOM
- ENTRY VESTIBULE
- EXEC OFFICE
- HALL
- LOBBY
- MECH & ELEC ROOM
- MENS
- OFFICE MANAGER
- RECEPTIONIST
- Room
- STAIR
- WOMENS
- WORK ROOM

LEVEL ONE. COLOR

# floor plan

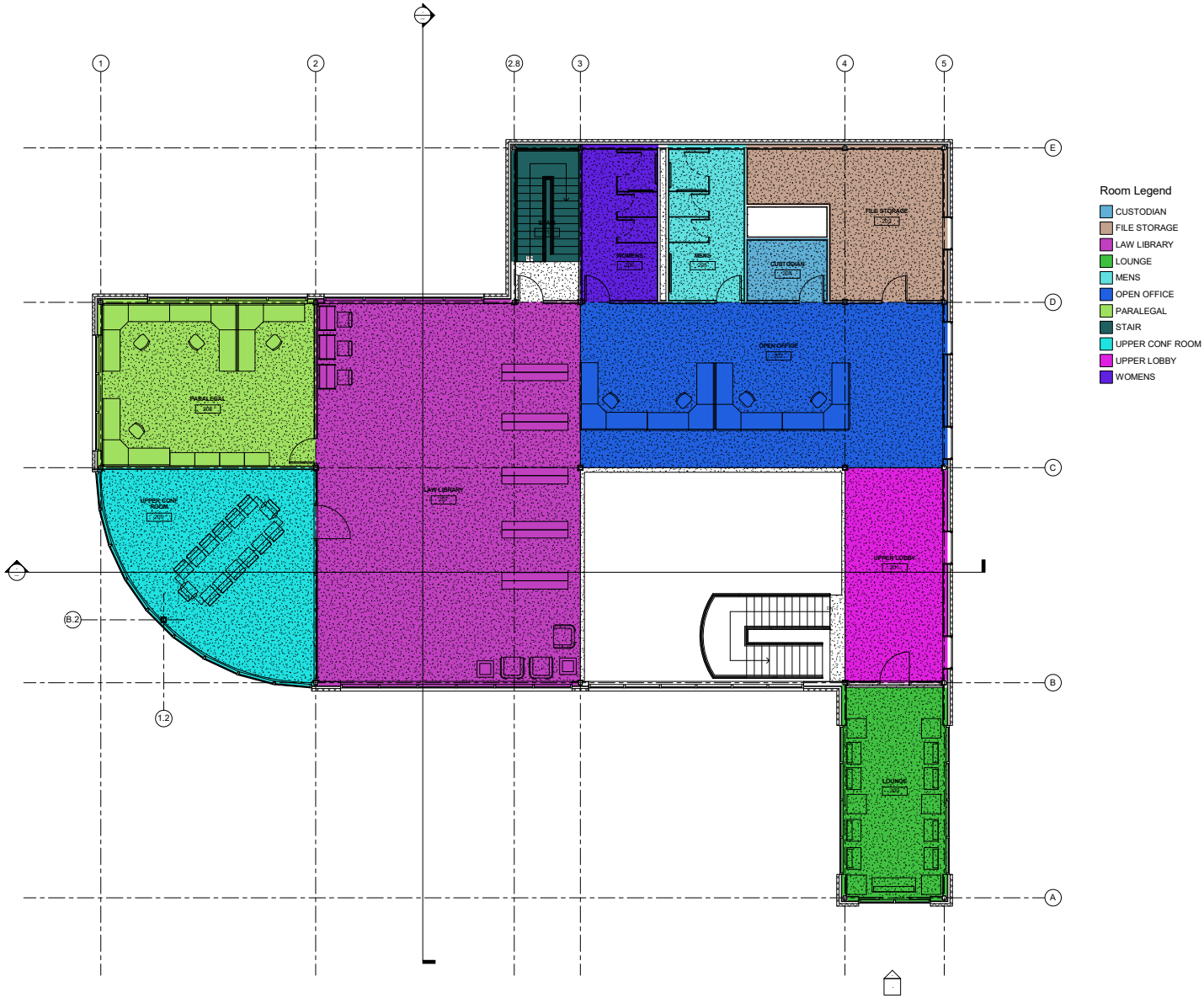

LEVEL TWO. COLOR

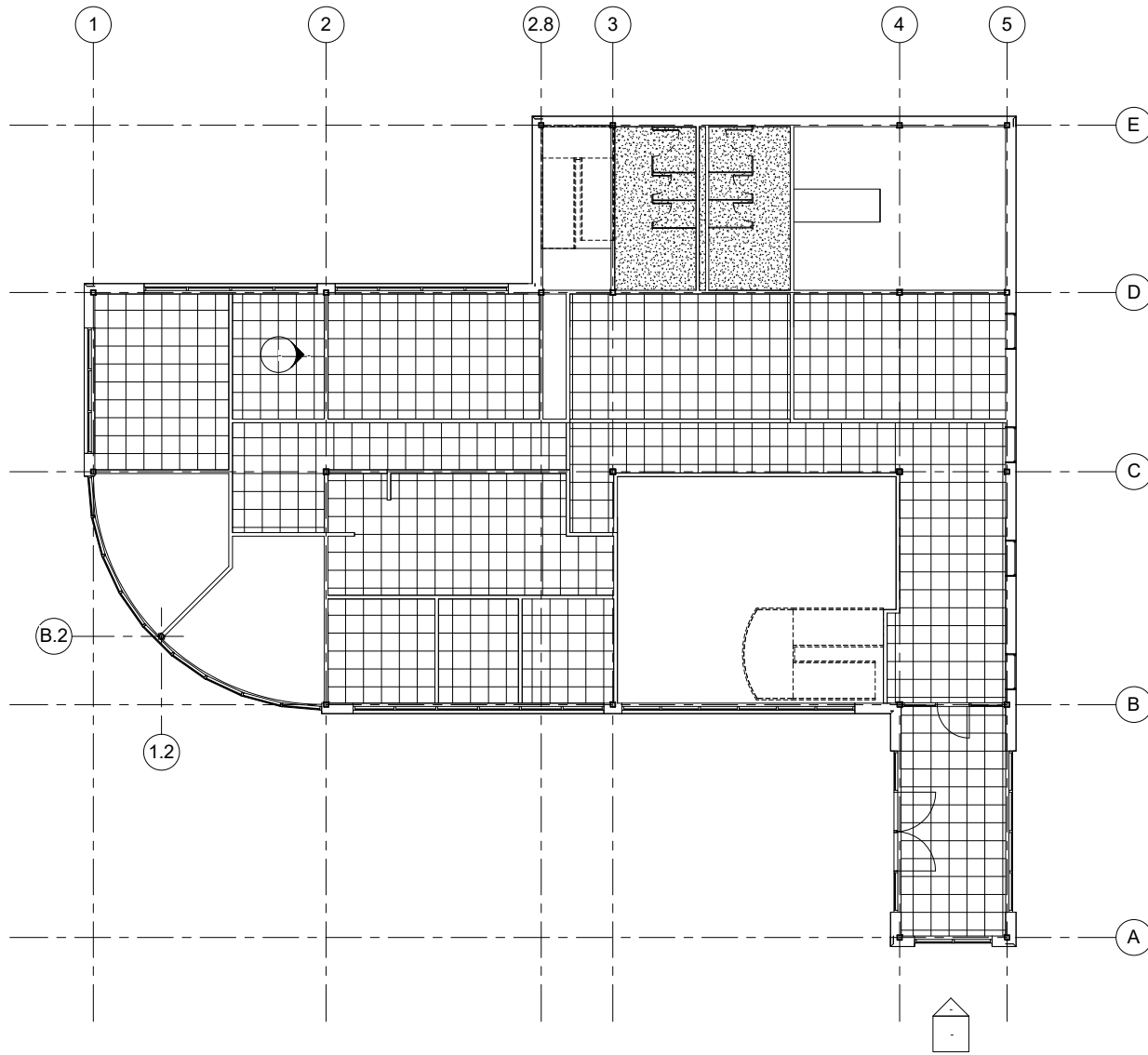

ceiling

REFLECTED CEILING PLAN - ONE

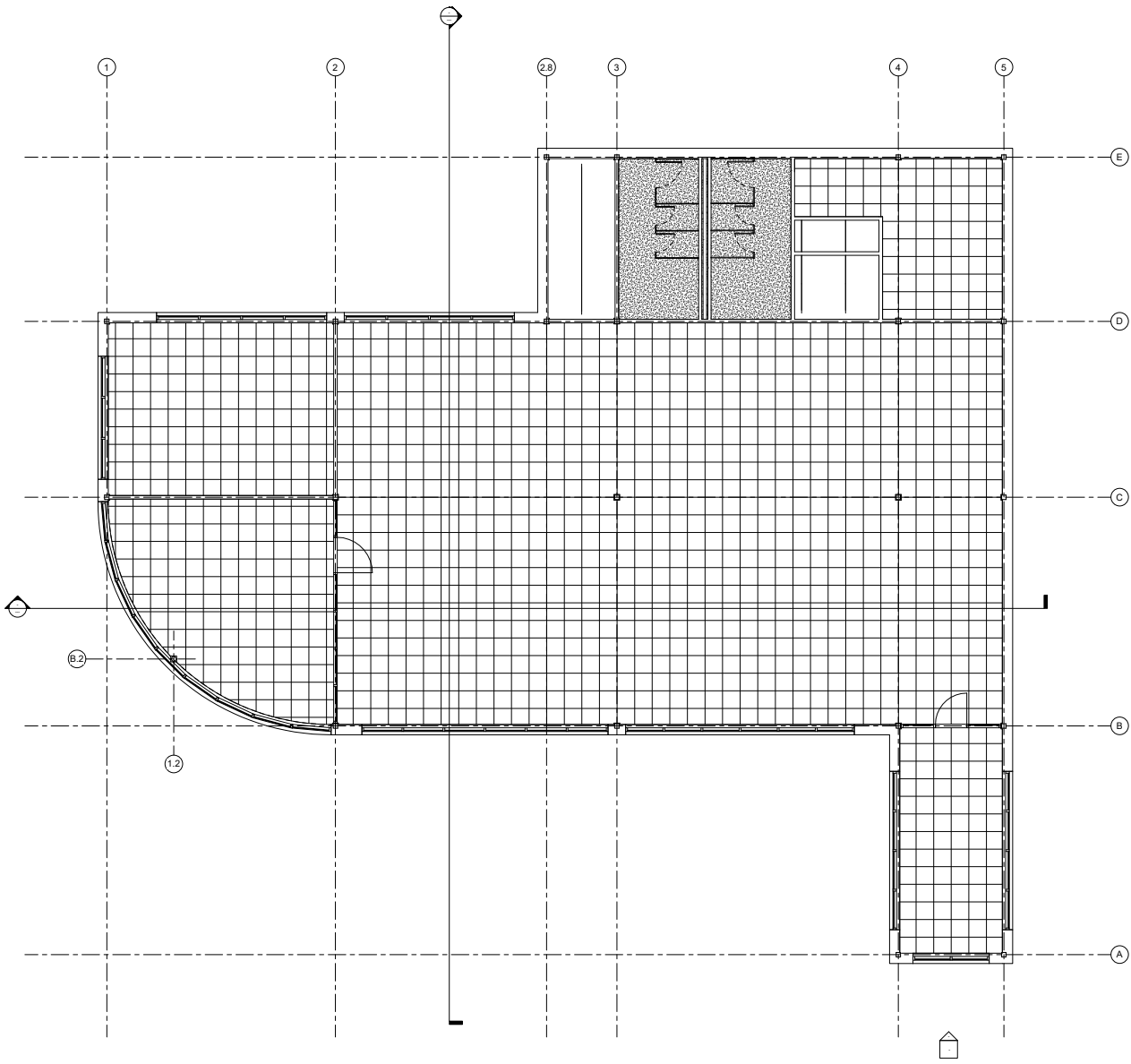

# Ceiling

REFLECTED CEILING PLAN - TWO

# schedule

LAW OFFICE COLUMN SCHEDULE																							
Roof																							Roof 28' - 8"
Level 2																							Level 2 13' - 4"
Level 1																							Level 1 0' - 0"
T.O. Footing																							T.O. Footing -5' - 0"
Column Locations	A-4	A-5	B-2	B-3	B-4	B-5	B.2-1.2	C-1	C-2	C-3	C-4	C-5	D-1	D-2	D-2.8	D-3	D-4	D-5	E-2.8	E-3	E-4	E-5	

LAW OFFICE COLUMN SCHEDULE

# Door Schedule

Door Schedule															
Door Number	Type	Door						Fire Rating	Hardware	Frame					Comments
		Width	Height	Thickness	Material	Finish	Under Cut			Type	Material	Finish	Jamb	Head	
100A	8	3' - 0"	7' - 0"	0' - 2"											
116	8	3' - 0"	7' - 0"	0' - 2"											
101	8	3' - 0"	7' - 0"	0' - 2"											
115B	8	3' - 0"	7' - 0"	0' - 2"											
102	8	3' - 0"	7' - 0"	0' - 2"											
104	8	3' - 0"	7' - 0"	0' - 2"											
105	8	3' - 0"	7' - 0"	0' - 2"											
106	8	3' - 0"	7' - 0"	0' - 2"											
107	8	3' - 0"	7' - 0"	0' - 2"											
108	8	3' - 0"	7' - 0"	0' - 2"											
111	8	3' - 0"	7' - 0"	0' - 2"											
112	8	3' - 0"	7' - 0"	0' - 2"											
113	8	3' - 0"	7' - 0"	0' - 2"											
110	8	3' - 0"	7' - 0"	0' - 2"											
115C	8	3' - 0"	7' - 0"	0' - 2"											
208	8	3' - 0"	7' - 0"	0' - 2"											
207	8	3' - 0"	7' - 0"	0' - 2"											
206	8	3' - 0"	7' - 0"	0' - 2"											
205	8	3' - 0"	7' - 0"	0' - 2"											
204	8	3' - 0"	7' - 0"	0' - 2"											
203	8	3' - 0"	7' - 0"	0' - 2"											
114A	16	5' - 0"	7' - 0"	0' - 1 1/2"											
114B	16	5' - 0"	7' - 0"	0' - 1 1/2"											
100B	24	6' - 0"	7' - 0"	0' - 2"											
118		8' - 9 1/2"	7' - 10 3/4"												
200	19	3' - 6 27/32"	7' - 8 1/4"												
115A	19	3' - 6 27/32"	7' - 8 1/4"												
209	19	4' - 0 7/16"	7' - 8 1/4"												

# schedule

Room Schedule							
Room Number	Room Name	Floor Finish	Base Finish	Wall Finish	Ceiling Finish	Ceiling Height	Comments
100	MECH & ELEC ROOM						
101	MENS	CT-1	COVED CT	CT-2	GYP BD		
102	WOMENS	CT-1	COVED CT	CT-2	GYP BD		
#1	STAIR						
104	CONF ROOM						
105	BREAK RM						
106	ASSOCIATES OFFICE	CPT-1	WOOD	VWC-1	ACT-1		
107	EXEC OFFICE						
108	EXEC OFFICE						
109	HALL						
110	ADMIN ASSIST						
111	OFFICE MANAGER	CPT-1	WOOD	VWC-1	ACT-1		
112	Room	CPT-1	WOOD	VWC-1	ACT-1		
113	Room	CPT-1	WOOD	VWC-1	ACT-1		
114	COAT CLOSET						
115	LOBBY						
116	WORK ROOM						
117	RECEPTIONIST						
118	ENTRY VESTIBULE						
200	LOUNGE						
201	UPPER LOBBY						
202	OPEN OFFICE						
203	FILE STORAGE						
204	CUSTODIAN						
205	MENS						
206	WOMENS						
207	LAW LIBRARY						
208	PARALEGAL						
209	UPPER CONF ROOM						

## LAW OFFICE ROOM SCHEDULE

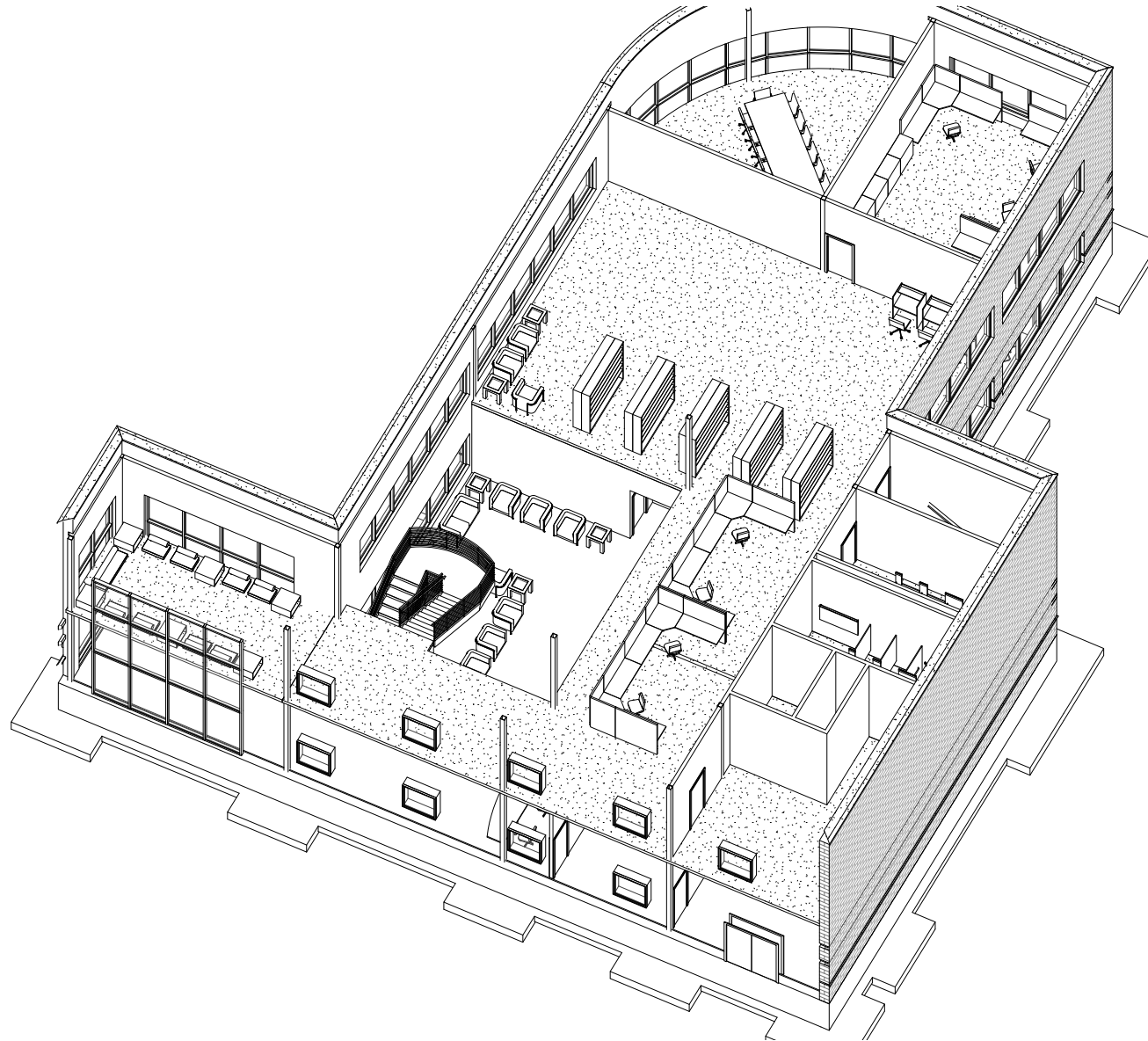

three.d

THREE D VIEW - HIDDEN ROOF, STRUCTURES AND EAST WALL